

capacitors

5MPA SERIES

METALLIZED POLYPROPYLENE

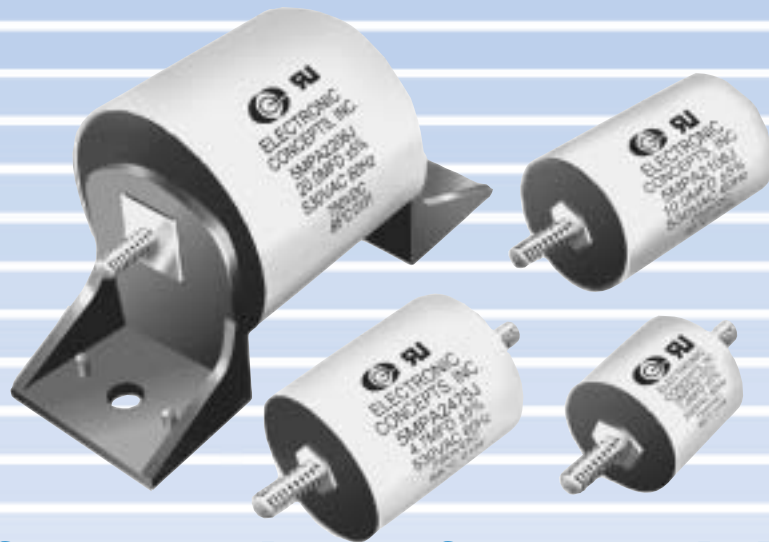

offers superior performance in high power AC filtering for motor run applications

- VOLTAGE OF 530VAC at 60Hz max., 750 VDC
- DRY FILM CONSTRUCTION
- CAPACITANCE TO 100 μ F
- CONTINUOUS OPERATING TEMPERATURE TO +85° C
- FLAME RETARDANT
- CURRENT HANDLING CAPABILITY TO 83.2 Arms

The **5MPA SERIES** represents an excellent solution for AC motor run applications where high PWM and other feedback currents are present on top of line frequency. The 5MPA is superior to other brands. This is due to its unique high current and frequency response terminations, plus a dry film construction.

There are two different types of terminal configurations, both with voltage ratings to 530 VAC. For capacitance values up to 10.0 μ F, there is a brass bolt termination.

Values up to 100.0 μ F are supplied with an exclusive "bridge & bolt" construction – both with multiple internal soldered contact points for high current distribution. Units are wrapped with flame retardant insulating sleeves and end-filled with a flame retardant potting compound. Current handling capabilities from normal line frequency currents to 83amps, RMS from 2kHz to resonant frequency. Each capacitor also undergoes a series of electrical property tests to ensure in-the-field quality.

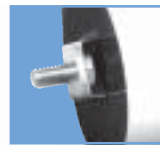

With the introduction of the **5MPA SERIES**, the designer now has a dry film AC capacitor with a combination of physical and electrical properties to maximize performance, reliability and space utilization. With the realistic potential for significant production and overall system cost savings.

electronic concepts



specifications

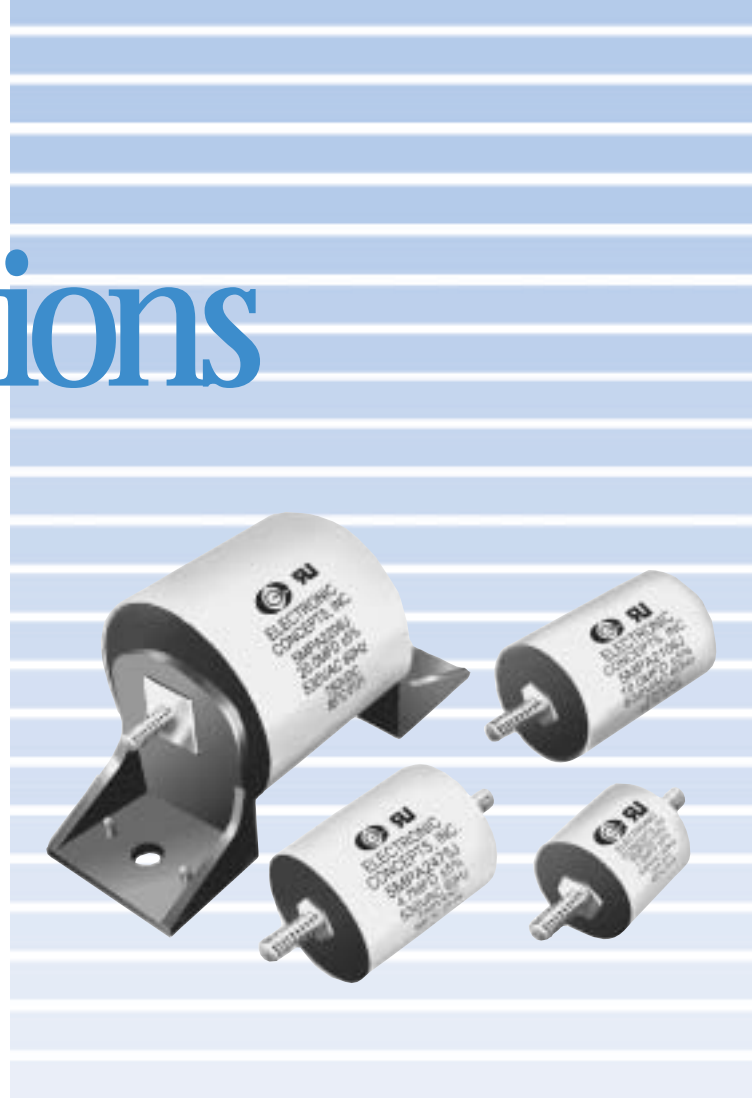

CONSTRUCTION

Extended foil.

SERVICE LIFE

Designed to meet the requirements of MIL-STD-202, Method 108, condition F.

HUMIDITY RESISTANCE

Exceeds requirements of MIL-STD-202, Method 103.

QUALITY CONTROL

Capacitors are tested 100% for:

- CAPACITANCE TOLERANCE
- DISSIPATION FACTOR
- DIELECTRIC WITHSTANDING VOLTAGE
- INSULATION RESISTANCE
- ESR

Complete process and inspection data is maintained on file and is available on special request.

MARKING

All capacitors are marked with one or more of the following: company initials "EC", corporate logo or EC trademark — in addition to style, capacitance, tolerance, rated DC working voltage and date code.

DATE CODE

The first two digits of the date code represent the year, the second two digits the week.

QUALITY ASSURANCE

Emphasis is placed on quality assurance. Raw material inspection and the use of SPC monitored manufacturing procedures assure highest quality standards. Procedures are fully described in the EC Quality Control Manual. Electronic Concepts will continue to advance the state-of-the-art by utilizing leading edge technology, ultra-miniature capacitor designs and established reliability procedures.

In constructing the components described, the full intent of the specification will be met. Electronic Concepts does, however, reserves the right to depart from the detail specifications in order to improve the design of its products.

This information is believed to be accurate and reliable. However, Electronic Concepts assumes no responsibility for its use; nor for any infringement of patents or other rights of third parties which may result.

how to order

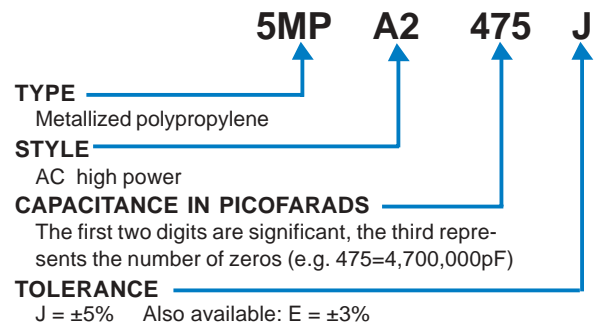

dimensional data

VOLTAGE RATINGS: 530VAC@60Hz MAX., 750 VDC

| PART NO | Value μF | E.S.R.* milli-ohms | E.S.L. nH | Fres kHz | I pk AMPS | dv/dt v/ μs | Arms 25°C | Arms 45°C | Arms 65°C | Arms 85°C | Diameter Max | Length $\pm 0.098''$ [2.4mm] |
|-----------|---------------------|-----------------------|--------------|-------------|--------------|---------------------------|--------------|--------------|--------------|--------------|-----------------|---------------------------------|
| 5MPA2105J | 1.0 | 3.1 | 11.5 | 1490 | 639 | 639 | 22.2 | 19.2 | 15.8 | 11.3 | 1.300[33.0mm] | 1.125 [28.6mm] |
| 5MPA2205J | 2.0 | 2.1 | 17.3 | 855 | 726 | 363 | 31.1 | 27.0 | 22.1 | 15.9 | 1.600[40.6mm] | 1.125[28.6mm] |
| 5MPA2475J | 4.7 | 1.2 | 24.0 | 474 | 1181 | 251 | 52.0 | 45.2 | 37.0 | 26.6 | 1.700[43.2mm] | 1.875[47.6mm] |
| 5MPA2106J | 10.0 | 1.5 | 48.7 | 228 | 1129 | 113 | 56.6 | 49.1 | 40.3 | 28.9 | 1.700[43.2mm] | 2.250[57.2mm] |

*ESR Measured at Resonant Frequency or 10m Ω MAX @10kHz

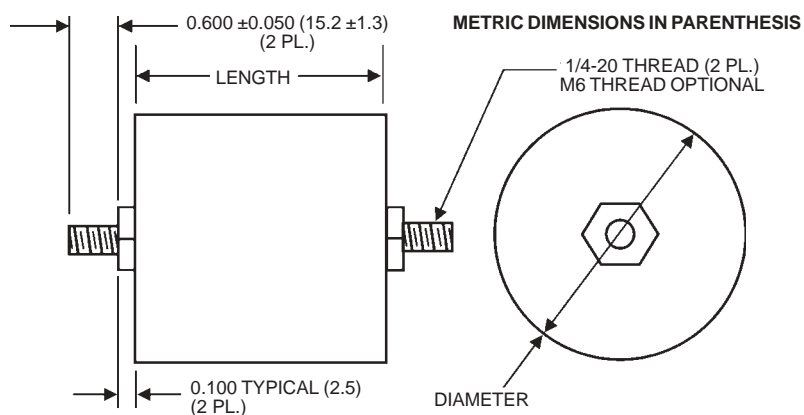

VOLTAGE RATINGS: 530VAC@60Hz MAX., 750 VDC

| PART NO | Value μF | E.S.R.* milli-ohms | E.S.L. nH | F res kHz | I pk AMPS | dv/dt v/ μs | Arms 25°C | Arms 45°C | Arms 65°C | Arms 85°C | Diameter Max | Length $\pm 0.098''$ [2.4mm] |
|-----------|---------------------|-----------------------|--------------|--------------|--------------|---------------------------|--------------|--------------|--------------|--------------|-----------------|---------------------------------|
| 5MPA2206J | 20.0 | 1.3 | 48.7 | 161.2 | 2709 | 135 | 65.8 | 57.1 | 46.8 | 33.6 | 2.800[71.1mm] | 2.375[60.3mm] |
| 5MPA2306J | 30.0 | 1.0 | 48.7 | 131.6 | 3725 | 124 | 83.9 | 72.8 | 59.8 | 42.9 | 3.200[81.3mm] | 2.375[60.3mm] |
| 5MPA2406J | 40.0 | 1.9 | 89.9 | 83.9 | 2903 | 73 | 64.2 | 55.7 | 45.7 | 32.8 | 2.800[71.7mm] | 3.750[82.6mm] |
| 5MPA2506J | 50.0 | 1.5 | 89.9 | 75.1 | 3629 | 73 | 77.0 | 66.9 | 54.9 | 39.4 | 3.200[81.3mm] | 3.750[82.6mm] |
| 5MPA2606J | 60.0 | 1.7 | 109.0 | 62.2 | 3811 | 64 | 78.7 | 68.3 | 56.0 | 40.2 | 3.200[81.3mm] | 4.375[111.1mm] |
| 5MPA2756J | 75.0 | 2.5 | 141.2 | 48.8 | 3372 | 49 | 66.0 | 57.3 | 47.0 | 33.7 | 2.800[71.1mm] | 5.375[136.5mm] |
| 5MPA2107J | 100.0 | 1.9 | 141.2 | 42.2 | 4496 | 45 | 83.2 | 72.2 | 59.2 | 42.5 | 3.200[81.3mm] | 5.375[136.5mm] |

*ESR Measured at Resonant Frequency or 5m Ω MAX @10kHz

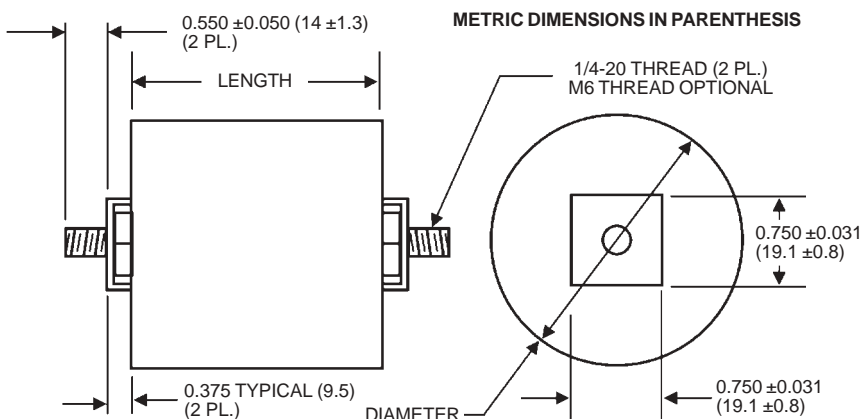

performance

CHARACTERISTICS

OPERATING TEMPERATURE RANGE

From -55°C to +85°C with 50% voltage derating from 85°C to 105°C.

INSULATION RESISTANCE

When measured at test temperature and rated voltage for a minimum of two (2) minutes, the insulation resistance equals or exceeds the following values:

| Temperature | 25°C | 85°C |
|-----------------------|--------|-------|
| Megohms x Microfarads | 25,000 | 5,000 |

Insulation resistance in megohms need not exceed: 25,000 5,000

DISSIPATION FACTOR

When measured at the frequency specified for capacitance measurement, the dissipation factor will not exceed 0.1%.

CAPACITANCE CHANGE

Capacitance change versus temperature for these capacitors shall not exceed the following:

| Temperature Degrees C. | -55 | +25 | +85 |
|------------------------|------|-----|------|
| Typical | +1.4 | 0 | -2.5 |

DIELECTRIC STRENGTH

Capacitors withstand a DC potential of 1000 VDC for one (1) minute without damage or breakdown. Test voltage is applied and discharged through a minimum resistance of 1 OHM per volt minimum.

CAPACITANCE TOLERANCE

Standard tolerance is ±5%. Tolerance of ±3% is also available.

NOTE: Capacitance is measured at 25°C, and at a frequency of 120Hz for all values.

sales offices

United States

Eastern

New Jersey
732-542-7880

Central

Illinois
630-668-8747

Western

California
805-582-9501

Europe

Ireland

Electronic Concepts, Ltd.

Oughterard

Co. Galway, Ireland
Tel: +353-91-552385, 552432
Fax: +353-91-552387
e-mail: sales@ecicaps.ie
www.electronicconcepts.ie

Middle East

Israel

Elind, Ltd.
P.O. Box 1615
Even-Yehuda 40500, Israel
Tel: +972-9899-1838
Fax: +972-9899-1822

US National Distribution Center

Elcon Sales

470 Clifton Ave.
Clifton, New Jersey 07011
Tel: 973-546-5022
Fax: 973-546-5523

Headquarters

Electronic Concepts, Inc.

P.O. Box 1278
Eatontown, New Jersey 07724
Tel: 732-542-7880
Fax: 732-542-0524
e-mail: sales@ecicaps.com
www.ecicaps.com

FOR ADDITIONAL INFORMATION
PLEASE CONTACT
ONE OF OUR REGIONAL OFFICES

electrical characteristics vs. temperature (centigrade)

insulation resistance versus temperature

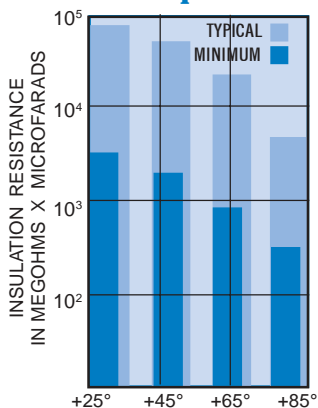

dissipation factor versus temperature

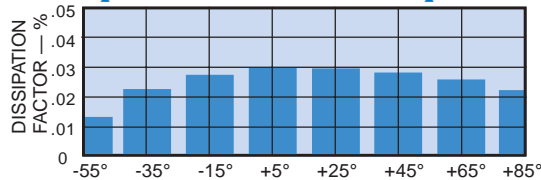

capacitance change versus temperature

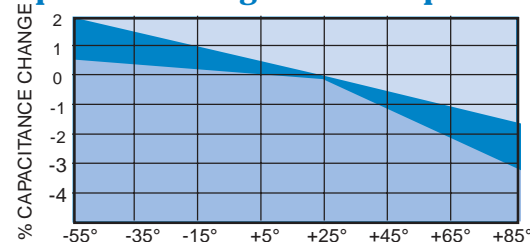

electronic concepts



526 Industrial Way West, Eatontown, New Jersey 07724 • TEL (732) 542-7880 • FAX (732) 542-0524
e-mail: sales@ecicaps.com www.ecicaps.com