

# 5MPA SERIES METALLIZED POLYPROPYLENE

## Metallized Polypropylene Low Loss Dry Film Construction Capacitors

UL Recognized Component. Superior to other AC capacitors because of low loss dry film construction.



### FEATURES

- Dry film construction
- Capacitance to 300 $\mu$ F
- Continuous operating temperature to 85°C
- High current handling
- UL recognized
- RoHS compliant

### STANDARD CONFIGURATION

- 4 Terminal Styles

# Specification Summary

## Capacitance Range

1.0 $\mu$ F to 300.0 $\mu$ F

## Capacitance Tolerance

Standard capacitance tolerance is  $\pm 5\%$ . Tolerance of  $\pm 3\%$  is also available.

## Operating Temperature Range

-55°C to +85°C

## Enclosure/Construction

Polypropylene film in a polyester wrap with epoxy endfill. Terminals are tin plated copper.

## Voltage Rating

VAC: 300VAC to 900VAC

VDC: 450VDC to 1300VDC

## Quality Control

Capacitors are tested 100% for:

- Capacitance
- Tolerance
- Dissipation Factor
- Dielectric withstanding voltage
- Insulation Resistance
- Equivalent Series Resistance (ESR)

Process and inspection data are maintained on file and available upon special request.

## Environmental

Parameter	Method	Condition
Vibration	204	D
Shock	213	I
Humidity	106	-
Thermal Shock	107	A
Life	108	F
Reference MIL-STD-202		

# Characteristics

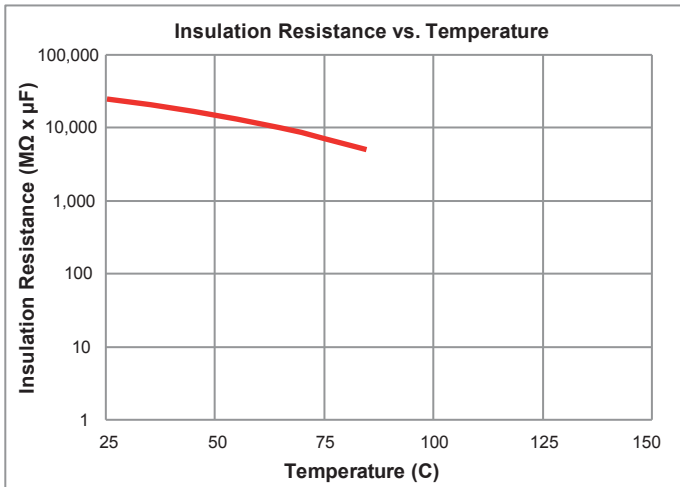

## Dielectric Strength

Capacitors withstand a DC potential of 1.5 x rated voltage for one (1) minute without damage or breakdown. Test voltage is applied and discharged through a minimum resistance of 1 OHM per volt minimum.

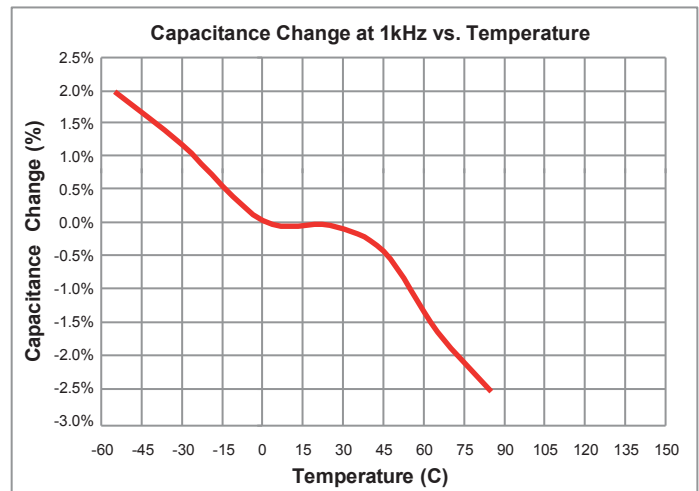

## Dissipation Factor

Polypropylene has an intrinsic dissipation factor of less than  $2.1 \times 10^{-4}$  over the operating temperature range of -55°C to +105°C and frequencies to 1MHz.

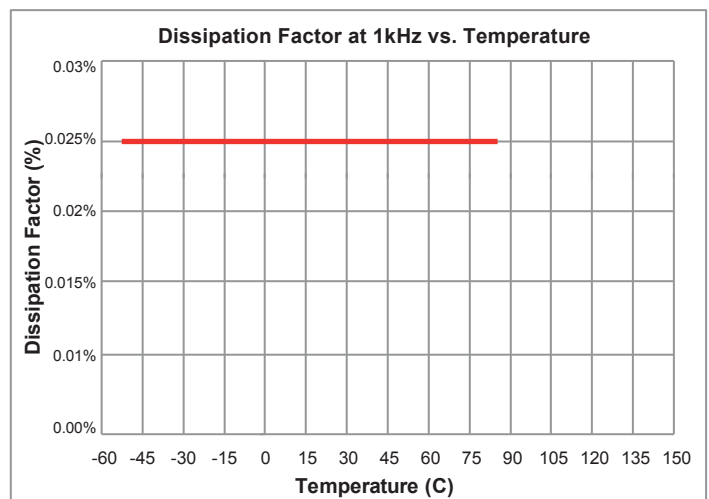

# Detail Data

PART NUMBER	CAP μF	VAC @60Hz	ESR mOhms	ESL nH	Fres kHz	I PEAK AMPS	dv/dt (V/μs)	TEMPERATURE				Diameter Max (mm)	Length ±0.098 (2.5mm)	STYLE	Bracket Spacing (mm)
								Arms							
								25°C	45°C	65°C	85°C				
5MPA1106_	10.0	300	3.6	21.0	345.0	760	76	25.8	22.3	18.1	12.7	1.500 (38.1)	1.250 (31.7)	2	-
5MPA1206_	20.0	300	4.2	35.0	191.0	937	47	28.2	24.1	19.4	13.3	1.650 (41.9)	1.750 (44.5)	2	-
5MPA1306_	30.0	300	2.8	35.0	156.0	1405	47	39.6	33.9	27.2	18.6	2.050 (52.0)	1.875 (47.6)	3	3.850 (97.8)
5MPA1406_	40.0	300	2.1	35.0	135.0	1874	47	50.3	43.1	34.5	23.5	2.300 (58.4)	1.875 (47.6)	3	3.850 (97.8)
5MPA1506_	50.0	300	1.7	35.0	121.0	2342	47	60.6	51.8	41.5	28.2	2.600 (66.0)	1.875 (47.6)	3	3.850 (97.8)
5MPA1756_	75.0	300	2.0	49.0	83.0	2538	34	58.9	50.0	39.5	25.9	2.700 (68.5)	2.375 (60.3)	3	4.400 (111.8)
5MPA1107_	100.0	300	2.0	57.0	68.0	2920	29	62.8	53.0	41.5	26.6	3.000 (76.2)	2.375 (60.3)	3	4.400 (111.8)
5MPA1207_	200.0	300	3.1	110.0	34.0	3207	16	51.2	41.4	30.0	15.1	3.050 (77.4)	4.375 (111.1)	3	6.375(161.9)
5MPA1307_	300.0	300	3.3	143.0	24.0	3809	13	48.7	37.8	24.9	8.3	3.200 (81.3)	5.375 (136.5)	3	7.350(186.7)
5MPA2105_	1.0	530	3.1	11.5	1490.0	639	639	22.2	19.2	15.8	11.3	1.300 (33.0)	1.125 (28.6)	4	-
5MPA2205_	2.0	530	2.1	17.3	855.0	726	363	31.1	27.0	22.1	15.9	1.600 (40.6)	1.125 (28.6)	4	-
5MPA2475_	4.7	530	1.2	24.0	474.0	1181	251	52.0	45.2	37.0	26.6	1.700 (43.2)	1.875 (47.6)	4	-
5MPA2106_	10.0	530	1.5	48.7	288.0	1129	113	56.6	49.1	40.3	28.9	1.700 (43.2)	2.250 (57.2)	4	-
5MPA2206_	20.0	530	1.3	48.7	161.2	2709	135	65.8	57.1	46.8	33.6	2.800 (71.1)	2.375 (60.3)	5	4.400 (111.8)
5MPA2306_	30.0	530	1.0	48.7	131.6	3725	124	83.9	72.8	59.8	42.9	3.200 (81.3)	2.375 (60.3)	5	4.400 (111.8)
5MPA2406_	40.0	530	1.9	89.9	83.9	2903	73	64.2	55.7	45.7	32.8	2.800 (71.7)	3.750 (82.6)	5	5.800 (147.3)
5MPA2506_	50.0	530	1.5	89.9	75.1	3629	73	77.0	66.9	54.9	39.4	3.200 (81.3)	3.750 (82.6)	5	5.800 (147.3)
5MPA2606_	60.0	530	1.7	109.0	62.2	3811	64	78.7	68.3	56.0	40.2	3.200 (81.3)	4.375 (111.1)	5	6.375 (161.9)
5MPA2756_	75.0	530	2.5	141.2	48.8	3372	49	66.0	57.3	47.0	33.7	2.800 (71.7)	5.375 (136.5)	5	7.350 (186.7)
5MPA2107_	100.0	530	1.9	141.2	42.2	4496	45	83.2	72.2	59.2	42.5	3.200 (81.3)	5.375 (136.5)	5	7.350 (186.7)
5MPA3505_	5.0	900	2.1	50.0	318.0	2017	403	45.5	39.3	31.9	22.4	2.400 (61.0)	2.375 (60.3)	5	4.400 (111.8)
5MPA3106_	10.0	900	1.1	50.0	225.0	4034	403	81.4	70.2	57.0	39.9	3.400 (86.4)	2.375 (60.3)	5	4.400 (111.8)
5MPA3206_	20.0	900	2.1	110.0	107.0	3305	165	63.8	54.5	43.5	29.3	3.100 (78.7)	4.375 (111.1)	5	6.375 (161.9)
5MPA3256_	25.0	900	1.7	110.0	95.0	4131	165	76.2	65.1	51.9	34.8	3.500 (88.9)	4.375 (111.1)	5	6.375 (161.9)
5MPA3306_	30.0	900	2.2	143.0	77.0	3810	127	67.8	57.5	45.3	29.6	3.300 (83.8)	5.375 (136.5)	5	7.350 (186.7)
5MPA3356_	35.0	900	1.9	143.0	71.0	4445	127	76.4	64.8	51.0	33.2	3.500 (88.9)	5.375 (136.5)	5	7.350 (186.7)

# Style

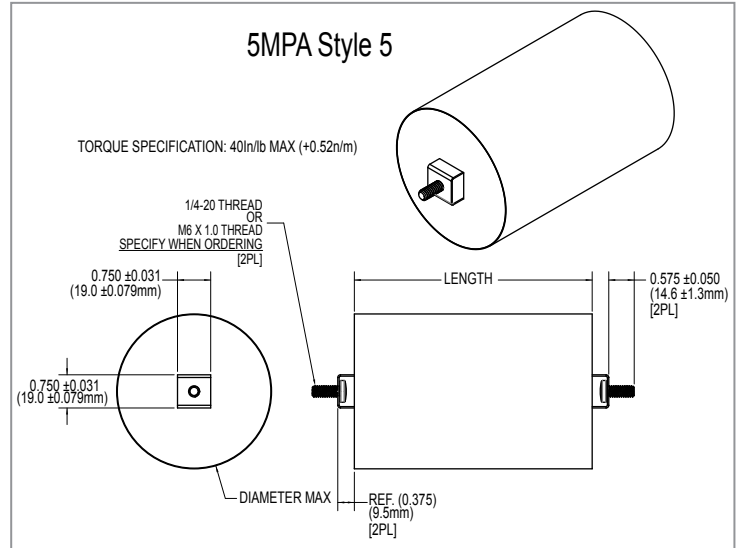
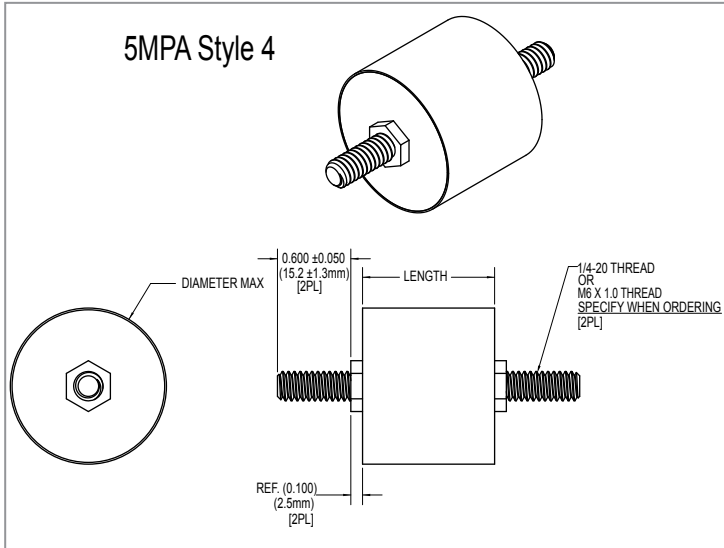
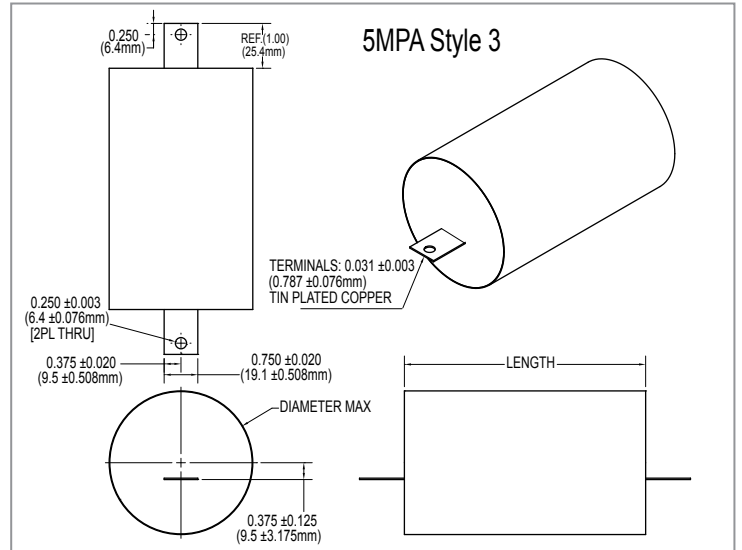
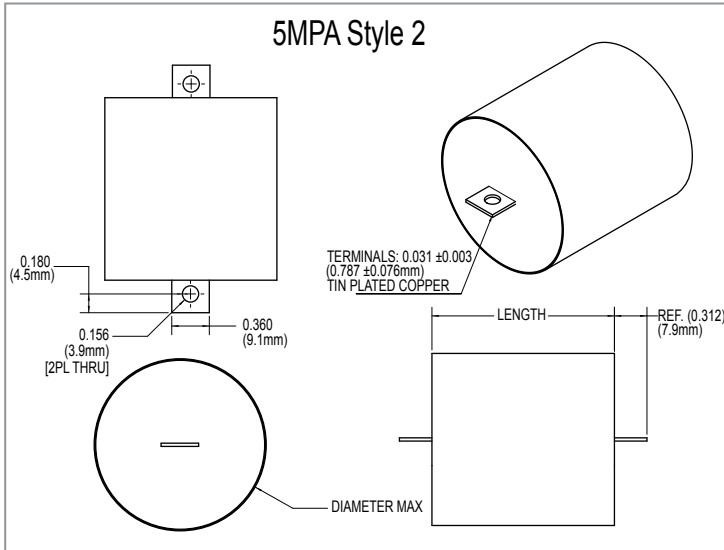

# Bracket

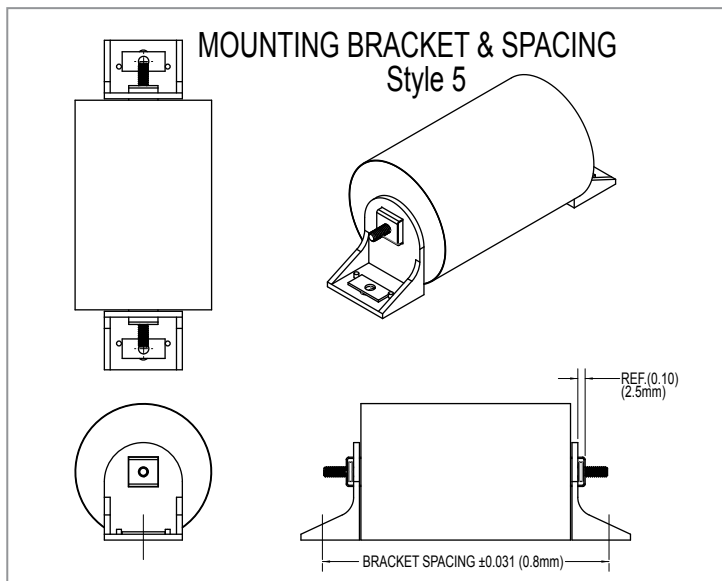
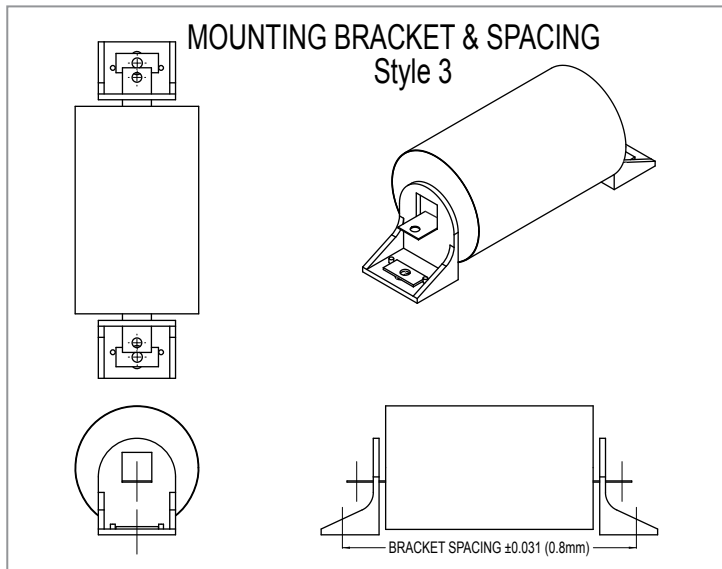
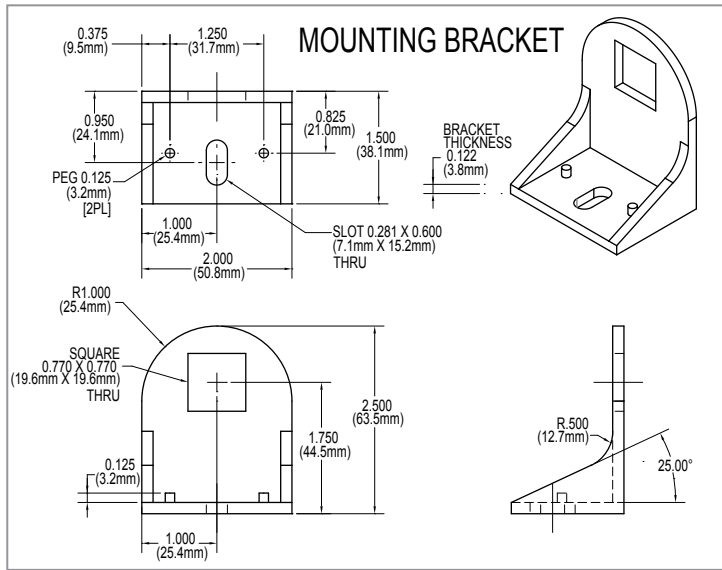

## Additional Information

Units are wrapped with flame retardant insulating tape and end-filled with a flame retardant potting compound. Current handling capabilities from normal line frequency currents to 83amps, RMS from 2kHz to resonant frequency. Capacitor values supporting style 5 are supplied with an exclusive "bridge & bolt" construction - both with multiple internal soldered contact points for high current distribution.

## How to Order

TYPE Metallized Polypropylene	→	<b>5MPA</b>
AC VOLTAGE 1 = 300 VAC, 2 = 530 VAC, 3 = 900 VAC	→	<b>2</b>
CAPACITANCE IN PICO FARADS The first two digits are significant, the third represents the number of zeros (e.g 475=4,700,000pF)	→	<b>475</b>
TOLERANCE J = ±5% Also available: E = ±3%	→	<b>J</b>
OPTIONS (WHERE APPLICABLE) No Suffix - Standard thread without brackets 2 - Standard threads with mounting brackets 3 - Metric threads without brackets 5 - Metric threads with mounting brackets 6 - Style 3 flat terminal tab with mounting brackets Standard thread: 1/4-20 Metric thread: M6 x 1.0	→	<b>2</b>
For terminal style 4 and style 5, in either standard or metric threads, hardware for electrical terminals only are available upon request. The hardware kit will include flat washers, nuts and lock washers.		

### Marking And Date Code

All capacitors are marked with company initials "EC", corporate logo or EC trademark—in addition to type 5MPA, capacitance, tolerance, rated DC working voltage and date code. The first two digits of the date code represent the year, the second two digits the week, i.e., 1252 is the 52nd week of 2012, 1202 is the second week of 2012.

### Quality Assurance

Major emphasis is placed on quality assurance. EC is an ISO 9001 and AS9100 Certified Company. Raw material inspection and the use of SPC manufacturing procedures assure the highest quality standards. Procedures are fully described in the EC Quality Control Manual. Electronic Concepts will continue to advance the state-of-the-art by utilizing leading edge technology, compact capacitor designs and establishing reliability procedures.

## Sales Offices

### United States Headquarters

Electronic Concepts, Inc.  
526 Industrial Way West  
Eatontown, NJ 07724  
Tel: 732-542-7880  
Fax: 732-542-0524

email: [sales@ecicaps.com](mailto:sales@ecicaps.com)  
website: [www.ecicaps.com](http://www.ecicaps.com)

### Distribution Center

Elcon Sales  
542 Industrial Way West  
Eatontown, NJ 07724  
Tel: 732-380-0405  
Fax: 732-380-0409

email: [sales@elconsales.com](mailto:sales@elconsales.com)

### European Headquarters

Electronic Concepts Europe LTD  
IDA Estate  
Oughterard  
Co. Galway  
Ireland  
tel: +353-91-552432  
fax: +353-91-552387

email: [sales@ecicaps.ie](mailto:sales@ecicaps.ie)  
website: [www.electronicconcepts.ie](http://www.electronicconcepts.ie)

