

UH3 Series - High Temperature Capacitors

The UH3 series provides high voltage, high temperature capacitors that are amazingly economical and practical.



FEATURES

- Operation to 125°C
- Low ESR and ESL
- Low cost
- Withstands hostile environments
- Integrated mounting flanges
- RoHS compliant

STANDARD CONFIGURATION

- UH31 Male Terminals
- UH32 Female Terminals

Specification Summary

Capacitance Range

25.0 μ F to 325.0 μ F

Capacitance Tolerance

Standard capacitance tolerance is $\pm 10\%$. Tolerances of $\pm 20\%$ and $\pm 5\%$ are also available.

Operating Temperature Range

-65°C to +125°C

Enclosure/Construction

Metallized polymer film potted in thermoplastic housing. Terminals are tin plated brass.

Voltage Rating

600 VDC to 1200 VDC

Quality Control

Capacitors are tested 100% for:

- Capacitance
- Tolerance
- Dissipation Factor
- Dielectric withstanding voltage
- Insulation Resistance
- Equivalent Series Resistance (ESR)

Process and inspection data are maintained on file and available upon special request.

Environmental

Parameter	Method	Condition
Vibration	204	D
Shock	213	I
Humidity	106	-
Thermal Shock	107	A
Life	108	F

Reference MIL-STD-202

Characteristics

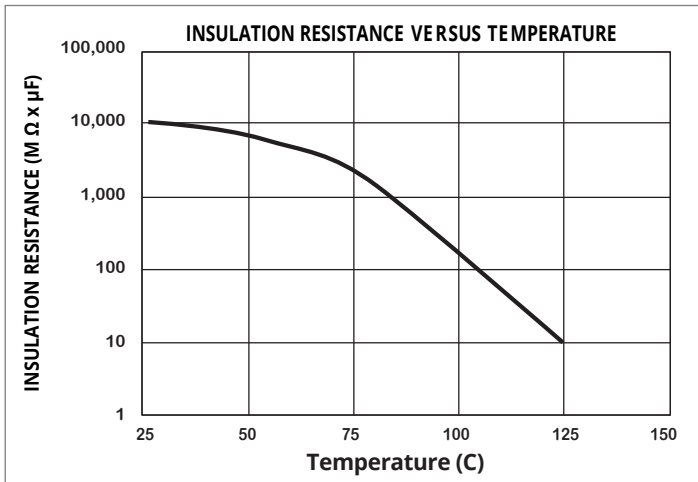

Dielectric Strength

Capacitors withstand a DC potential of 120% rated voltage for one (1) minute without damage or breakdown. Test voltage is applied and discharged through a resistance of 1 OHM per volt minimum, and at 25°C.

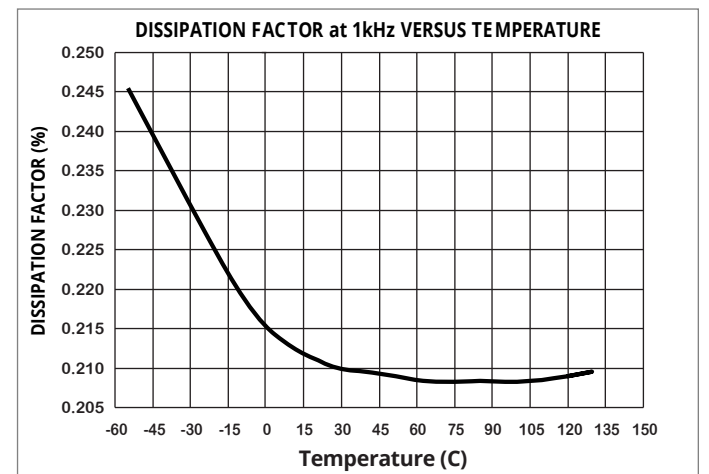
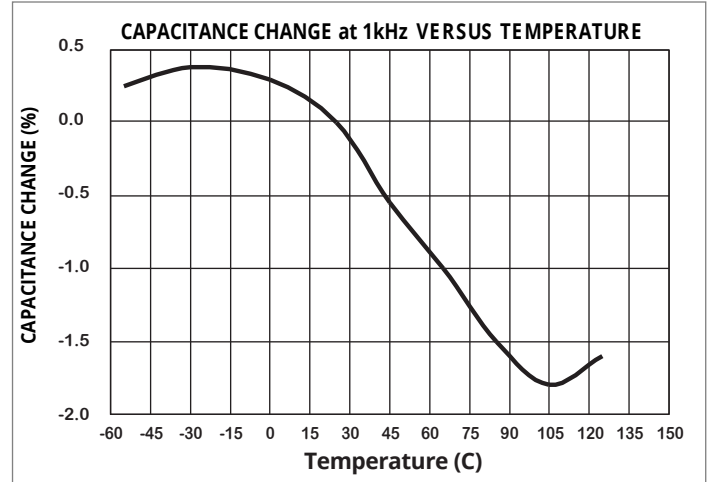

Detail Data

UH31, UH32														
ELECTRICAL SPECIFICATIONS														
PART NUMBER	VOLTAGE VDC	VALUE uF	CASE STYLE	"L" nH	Fres kHz	I pk	dv/dt	10 kHz E.S.R mOHMS	CURRENT RATING (AMPS RMS)					
									10 kHz CONTINUOUS					
									AMBIENT TEMPERATURE					
								25°C	45°C	65°C	85°C	105°C	125°C	
UH3_BC117	600	110	1	50	67	3456	29	4	62	56	48	40	29	9
UH3_BC327	600	325	2	60	36	6685	21	3	99	85	74	61	44	13
UH3_BJ506	900	50	1	50	101	2152	43	6	51	45	40	33	24	7
UH3_BJ147	900	140	2	60	55	4320	31	5	78	67	58	48	35	10
UH3_BN256	1200	25	1	50	142	1435	57	9	39	35	31	25	18	6
UH3_BN756	1200	75	2	60	75	3085	41	7	64	55	48	39	29	9

Style

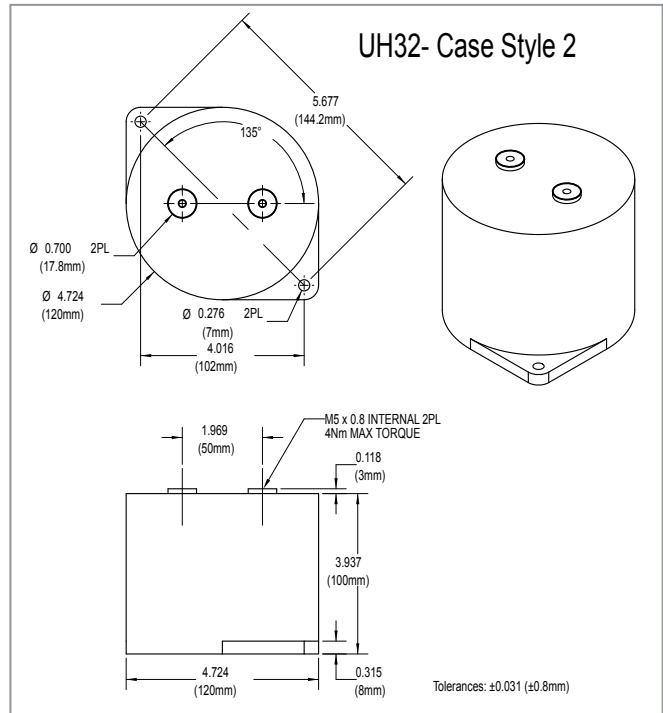
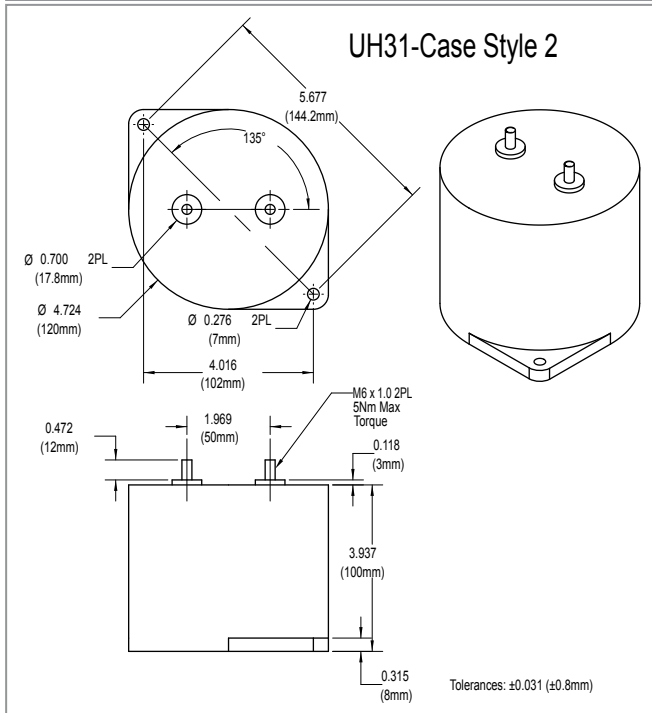
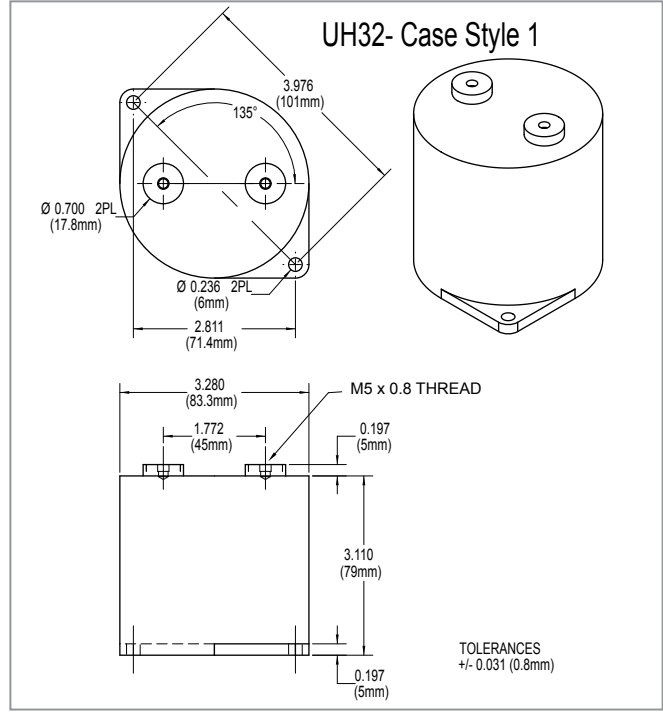
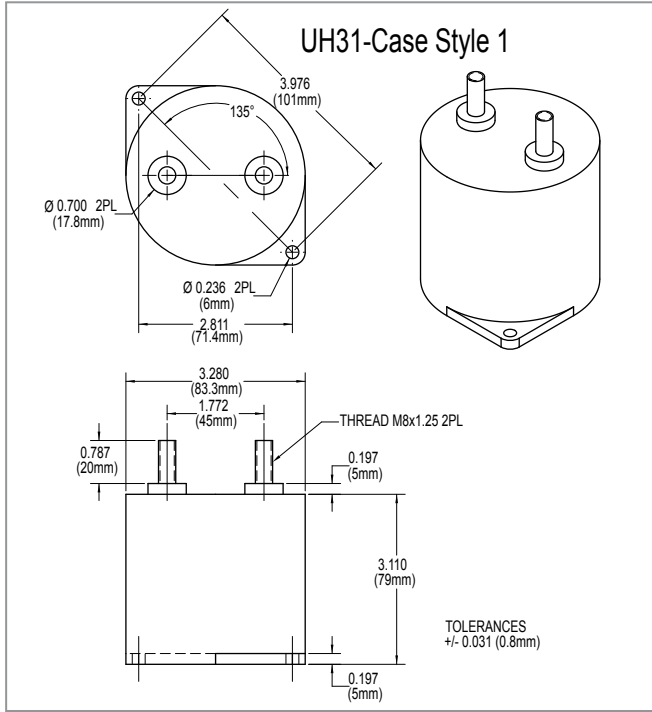

Additional Information

The combination of physical and electrical properties it offers encompasses low inductance with high current carrying capability – and a low profile to make the most efficient use of system space and increased cooling efficiency. Plus an in-house developed, “specific to the task” thermoplastic formulation for the enclosure, improves thermal conductivity. There is also an integrated flange with pre-drilled holes to simplify mounting.

How to Order

TYPE UH- High Temperature Polymer	→	UH
STYLE UH31 - Male, UH32 - Female	→	31
VOLTAGE DC Voltage Rating: C=600, J=900, N=1200	→	C
CAPACITANCE IN PICO FARADS The first two digits are significant figures, the third digit represents the number of zeros to follow to express the capacitance in picofarads.	→	157
Tolerance Standard tolerance is ±10%. Tolerances of ±5% and ±20% are also available.	→	K

Marking And Date Code

All capacitors are marked with company initials "EC", corporate logo or EC trademark—in addition to type UH3, capacitance, tolerance, rated DC working voltage and date code. The first two digits of the date code represent the year, the second two digits the week, i.e., 1252 is the 52nd week of 2012, 1202 is the second week of 2012.

Quality Assurance

Major emphasis is placed on quality assurance. EC is an ISO 9001 and AS9100 Certified Company. Raw material inspection and the use of SPC manufacturing procedures assure the highest quality standards. Procedures are fully described in the EC Quality Control Manual. Electronic Concepts will continue to advance the state-of-the-art by utilizing leading edge technology, compact capacitor designs and establishing reliability procedures.

Sales Offices

United States Headquarters

Electronic Concepts, Inc.
526 Industrial Way West
Eatontown, NJ 07724
Tel: 732-542-7880
Fax: 732-542-0524

email: sales@ecicaps.com
website: www.ecicaps.com

Distribution Center

Elcon Sales
542 Industrial Way West
Eatontown, NJ 07724
Tel: 732-380-0405
Fax: 732-380-0409

email: sales@elconsales.com

European Headquarters

Electronic Concepts Europe LTD
IDA Estate
Oughterard
Co. Galway
Ireland
tel: +353-91-552432
fax: +353-91-552387

email: sales@ecicaps.ie
website: www.electronicconcepts.ie